

# GATE SOLVED PAPER - ME

## REFRIGERATION AND AIR-CONDITIONING

YEAR 2013

ONE MARK

- Q. 1 The pressure, dry bulb temperature and relative humidity of air in a room are 1 bar, 30°C and 70%, respectively. If the saturated pressure at 30°C is 4.25 kPa, the specific humidity of the room air in kg water vapour/kg dry air is
- (A) 0.0083 (B) 0.0101  
(C) 0.0191 (D) 0.0232

YEAR 2012

TWO MARKS

### Common Data For Q. 2 and 3

A refrigerator operates between 120 kPa and 800 kPa in an ideal vapour compression cycle with R-134a as the refrigerant. The refrigerant enters the compressor as saturated vapour and leaves the condenser as saturated liquid. The mass flow rate of the refrigerant is 0.2 kg/s. Properties for R134a are as follows :

Saturated R-134a					
p(kPa)	T(°C)	$h_f$ (kJ/kg)	$h_g$ (kJ/kg)	$s_f$ (kJ/kgK)	$s_g$ (kJ/kgK)
120	-22.32	22.5	237	0.093	0.95
800	31.31	95.5	267.3	0.354	0.918
Superheated R-134a					
p(kPa)		T(°C)	h(kJ/kg)		s(kJ/kgK)
800		40	276.45		0.95

- Q. 2 The rate at which heat is extracted, in kJ/s from the refrigerated space is
- (A) 28.3 (B) 42.9  
(C) 34.4 (D) 14.6
- Q. 3 The power required for the compressor in kW is
- (A) 5.94 (B) 1.83  
(C) 7.9 (D) 39.5

YEAR 2011

ONE MARK

- Q. 4 If a mass of moist air in an airtight vessel is heated to a higher temperature, then
- (A) specific humidity of the air increases  
(B) specific humidity of the air decreases  
(C) relative humidity of the air increases  
(D) relative humidity of the air decreases

YEAR 2010

ONE MARK

- Q. 5 A moist air sample has dry bulb temperature of  $30^{\circ}\text{C}$  and specific humidity of  $11.5\text{ g water vapour per kg dry air}$ . Assume molecular weight of air as  $28.93$ . If the saturation vapour pressure of water at  $30^{\circ}\text{C}$  is  $4.24\text{ kPa}$  and the total pressure is  $90\text{ kPa}$ , then the relative humidity (in %) of air sample is
- (A) 50.5 (B) 38.5  
(C) 56.5 (D) 68.5

YEAR 2009

ONE MARK

- Q. 6 In an ideal vapour compression refrigeration cycle, the specific enthalpy of refrigerant (in  $\text{kJ/kg}$ ) at the following states is given as:
- Inlet of condenser :283  
Exit of condenser :116  
Exit of evaporator :232
- The COP of this cycle is
- (A) 2.27 (B) 2.75  
(C) 3.27 (D) 3.75

YEAR 2008

TWO MARKS

- Q. 7 Moist air at a pressure of  $100\text{ kPa}$  is compressed to  $500\text{ kPa}$  and then cooled to  $35^{\circ}\text{C}$  in an aftercooler. The air at the entry to the aftercooler is unsaturated and becomes just saturated at the exit of the aftercooler. The saturation pressure of water at  $35^{\circ}\text{C}$  is  $5.628\text{ kPa}$ . The partial pressure of water vapour (in  $\text{kPa}$ ) in the moist air entering the compressor is closest to
- (A) 0.57 (B) 1.13  
(C) 2.26 (D) 4.52
- Q. 8 Air (at atmospheric pressure) at a dry bulb temperature of  $40^{\circ}\text{C}$  and wet bulb temperature of  $20^{\circ}\text{C}$  is humidified in an air washer operating with continuous water recirculation. The wet bulb depression (i.e. the difference between the dry and wet bulb temperature) at the exit is 25% of that at the inlet. The dry bulb temperature at the exit of the air washer is closest to
- (A)  $10^{\circ}\text{C}$  (B)  $20^{\circ}\text{C}$   
(C)  $25^{\circ}\text{C}$  (D)  $30^{\circ}\text{C}$

YEAR 2007

TWO MARKS

- Q. 9 A building has to be maintained at  $21^{\circ}\text{C}$  (dry bulb) and  $14.5^{\circ}\text{C}$  (wet bulb). The dew point temperature under these conditions is  $10.17^{\circ}\text{C}$ . The outside temperature is  $-23^{\circ}\text{C}$  (dry bulb) and the internal and external surface heat transfer coefficients are  $8\text{ W/m}^2\text{K}$  and  $23\text{ W/m}^2\text{K}$  respectively. If the building wall has a thermal conductivity of  $1.2\text{ W/m K}$ , the minimum thickness (in m) of the wall required to prevent condensation is
- (A) 0.471 (B) 0.407  
(C) 0.321 (D) 0.125

- Q. 10 Atmospheric air at a flow rate of 3 kg/s (on dry basis) enters a cooling and dehumidifying coil with an enthalpy of 85 kJ/kg of dry air and a humidity ratio of 19 grams/kg of dry air. The air leaves the coil with an enthalpy of 43 kJ/kg of dry air and a humidity ratio of 8 grams/kg of dry air. If the condensate water leaves the coil with an enthalpy of 67 kJ/kg, the required cooling capacity of the coil in kW is
- (A) 75.0 (B) 123.8  
(C) 128.2 (D) 159.0

YEAR 2006

ONE MARK

- Q. 11 Dew point temperature is the temperature at which condensation begins when the air is cooled at constant
- (A) volume  
(B) entropy  
(C) pressure  
(D) enthalpy

YEAR 2006

TWO MARKS

- Q. 12 The statements concern psychrometric chart.
1. Constant relative humidity lines are uphill straight lines to the right
  2. Constant wet bulb temperature lines are downhill straight lines to the right
  3. Constant specific volume lines are downhill straight lines to the right
  4. Constant enthalpy lines are coincident with constant wet bulb temperature lines
- Which of the statements are correct ?
- (A) 2 and 3 (B) 1 and 2  
(C) 1 and 3 (D) 2 and 4

YEAR 2005

ONE MARK

- Q. 13 For a typical sample of ambient air (at 35° C, 75% relative humidity and standard atmosphere pressure), the amount of moisture in kg per kg of dry air will be approximately
- (A) 0.002 (B) 0.027  
(C) 0.25 (D) 0.75
- Q. 14 Water at 42° C is sprayed into a stream of air at atmospheric pressure, dry bulb temperature of 40° C and a wet bulb temperature of 20° C. The air leaving the spray humidifier is not saturated. Which of the following statements is true ?
- (A) Air gets cooled and humidified  
(B) Air gets heated and humidified  
(C) Air gets heated and dehumidified  
(D) Air gets cooled and dehumidified

YEAR 2005

TWO MARKS

Q. 15

The vapour compression refrigeration cycle is represented as shown in the figure below, with state 1 being the exit of the evaporator. The coordinate system used in this figure is

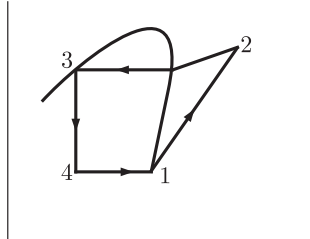

- (A)  $p-h$
- (B)  $T-s$
- (C)  $p-s$
- (D)  $T-h$

Q. 16

Various psychrometric processes are shown in the figure below.

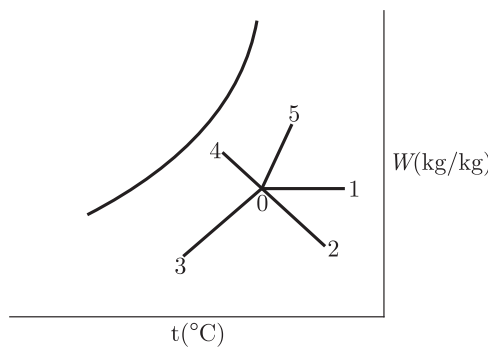

	Process in Figure		Name of the process
<b>P.</b>	0 - 1	<b>(i).</b>	Chemical dehumidification
<b>Q.</b>	0 - 2	<b>(ii).</b>	Sensible heating
<b>R.</b>	0 - 3	<b>(iii).</b>	Cooling and dehumidification
<b>S.</b>	0 - 4	<b>(iv).</b>	Humidification with steam injection
<b>T.</b>	0 - 5	<b>(v).</b>	Humidification with water injection

The matching pairs are

- (A) P-(i), Q-(ii), R-(iii), S-(iv), T-(v)
- (B) P-(ii), Q-(i), R-(iii), S-(v), T-(iv)
- (C) P-(ii), Q-(i), R-(iii), S-(iv), T-(v)
- (D) P-(iii), Q-(iv), R-(v), S-(i), T-(ii)

Q. 17

A vapour absorption refrigeration system is a heat pump with three thermal reservoirs as shown in the figure. A refrigeration effect of 100 W is required at 250 K when the heat source available is at 400 K. Heat rejection occurs at 300 K. The minimum value of heat required (in W) is

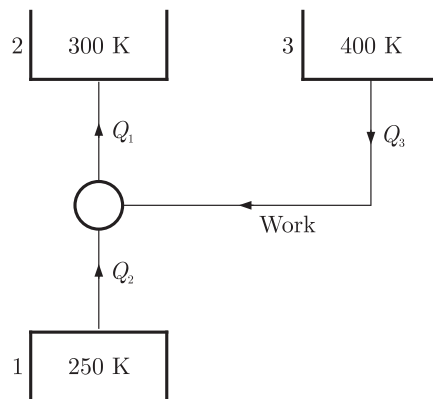

- (A) 167  
(B) 100  
(C) 80  
(D) 20

YEAR 2004

ONE MARK

- Q. 18 In the window air conditioner, the expansion device used is  
(A) capillary tube (B) thermostatic expansion valve  
(C) automatic expansion valve (D) float valve
- Q. 19 During the chemical dehumidification process of air  
(A) dry bulb temperature and specific humidity decreases  
(B) dry bulb temperature increases and specific humidity decreases  
(C) dry bulb temperature decreases and specific humidity increases  
(D) dry bulb temperature and specific humidity increases
- Q. 20 Environment friendly refrigerant R134 is used in the new generation domestic refrigerators. Its chemical formula is  
(A)  $\text{CHClF}_2$  (B)  $\text{C}_2\text{Cl}_3\text{F}_3$   
(C)  $\text{C}_2\text{Cl}_2\text{F}_4$  (D)  $\text{C}_2\text{H}_2\text{F}_4$

YEAR 2004

TWO MARKS

- Q. 21 A heat engine having an efficiency of 70% is used to drive a refrigerator having a coefficient of performance of 5. The energy absorbed from low temperature reservoir by the refrigerator for each kJ of energy absorbed from high temperature source by the engine is  
(A) 0.14 kJ (B) 0.71 kJ  
(C) 3.5 kJ (D) 7.1 kJ
- Q. 22 Dew point temperature of air at one atmospheric pressure (1.013 bar) is  $18^\circ\text{C}$ . The air dry bulb temperature is  $30^\circ\text{C}$ . The saturation pressure of water at  $18^\circ\text{C}$  and  $30^\circ\text{C}$  are 0.02062 bar and 0.04241 bar respectively. The specific heat of air and water vapour respectively are 1.005 and 1.88 kJ/kg K and the latent heat of vaporization of water at  $0^\circ\text{C}$  is 2500 kJ/kg. The specific humidity (kg/kg of dry air) and enthalpy (kJ/kg or dry air) of this moist air respectively, are  
(A) 0.01051, 52.64 (B) 0.01291, 63.15  
(C) 0.01481, 78.60 (D) 0.01532, 81.40

Q. 23

A R-12 refrigerant reciprocating compressor operates between the condensing temperature of  $30^{\circ}\text{C}$  and evaporator temperature of  $-20^{\circ}\text{C}$ . The clearance volume ratio of the compressor is 0.03. Specific heat ratio of the vapour is 1.15 and the specific volume at the suction is  $0.1089\text{ m}^3/\text{kg}$ . Other properties at various states are given in the figure. To realize 2 tons of refrigeration, the actual volume displacement rate considering the effect of clearance is

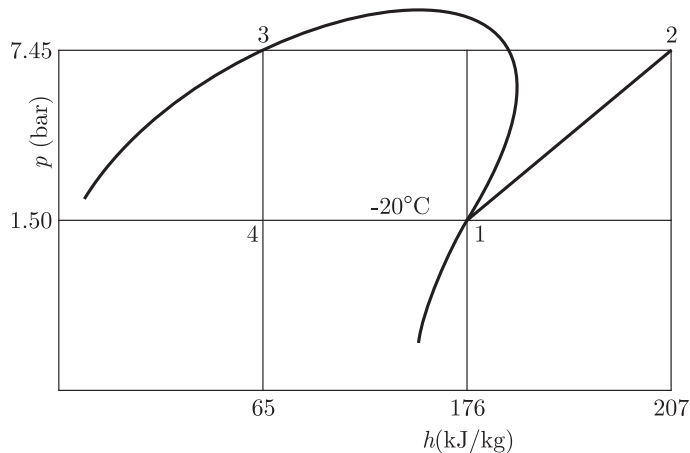

- (A)  $6.35 \times 10^{-3}\text{ m}^3/\text{s}$   
 (B)  $63.5 \times 10^{-3}\text{ m}^3/\text{s}$   
 (C)  $635 \times 10^{-3}\text{ m}^3/\text{s}$   
 (D)  $4.88 \times 10^{-3}\text{ m}^3/\text{s}$

YEAR 2003

ONE MARK

Q. 24

An industrial heat pump operates between the temperatures of  $27^{\circ}\text{C}$  and  $-13^{\circ}\text{C}$ . The rates of heat addition and heat rejection are  $750\text{ W}$  and  $1000\text{ W}$ , respectively. The COP for the heat pump is

- (A) 7.5  
 (B) 6.5  
 (C) 4.0  
 (D) 3.0

Q. 25

For air with a relative humidity of 80%

- (A) the dry bulb temperature is less than the wet bulb temperature  
 (B) the dew point temperature is less than wet bulb temperature  
 (C) the dew point and wet bulb temperature are equal  
 (D) the dry bulb and dew point temperature are equal

**Common Data For Q.26 and Q.27**

A refrigerator based on ideal vapour compression cycle operates between the temperature limits of  $-20^{\circ}\text{C}$  and  $40^{\circ}\text{C}$ . The refrigerant enters the condenser as saturated vapour and leaves as saturated liquid. The enthalpy and entropy values for saturated liquid and vapour at these temperatures are given in the table below.

T ( $^{\circ}\text{C}$ )	$h_f$ (kJ/kg)	$h_g$ (kJ/kg)	$s_f$ (kJ/kg K)	$s_g$ (kJ/kg K)
-20	20	180	0.07	0.7366
40	80	200	0.3	0.67

- Q. 26 If refrigerant circulation rate is 0.025 kg/s, the refrigeration effect is equal to  
(A) 2.1 kW (B) 2.5 kW  
(C) 3.0 kW (D) 4.0 kW
- Q. 27 The COP of the refrigerator is  
(A) 2.0 (B) 2.33  
(C) 5.0 (D) 6.0

\*\*\*\*\*

# SOLUTION

Sol. 1

Option (C) is correct.

Specific humidity is given by

$$w = 0.622 \times \frac{p_v}{p_a - p_v} \quad \dots(i)$$

where

$$p_v = \text{Relative humidity} \times \text{Saturated steam pressure} = \phi \times p_s \\ = 0.7 \times 0.0425 = 0.02975 \text{ bar}$$

So that from equation (i), we have

$$w = 0.622 \times \frac{0.02975}{1 - 0.02975} \quad p_a = 1 \text{ bar} \\ = 0.0191 \text{ kg/kg of dry air}$$

Sol. 2

Option (A) is correct.

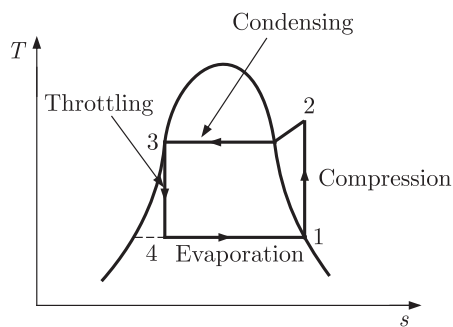
 $T$ - $s$  diagram for given Refrigeration cycle is given above

Since Heat is extracted in evaporation process.

So rate of heat extracted  $= \dot{m}(h_1 - h_4)$ From above diagram ( $h_3 = h_4$ ) for throttling process, so

$$\text{Heat extracted} = \dot{m}(h_1 - h_3)$$

From given table

$$h_1 = h_g \text{ at } 120 \text{ kPa, } h_g = 237 \text{ kJ/kg}$$

$$h_3 = h_f \text{ at } 120 \text{ kPa, } h_f = 95.5 \text{ kJ/kg}$$

$$\text{Hence Heat extracted} = \dot{m}(h_g - h_f) = 0.2 \times (237 - 95.5) \\ = 28.3 \text{ kJ/s}$$

Sol. 3

Option (C) is correct.

Since power is required for compressor in refrigeration is in compression cycle (1-2)

$$\text{Hence, Power required} = \dot{m}(h_2 - h_1) = \dot{m}(h_2 - h_f)$$

Since for isentropic compression process.

$$s_1 = s_2 \text{ from figure.} = 0.95$$

For entropy  $s = 0.95$  the enthalpy  $h = 276.45 \text{ kJ/kg}$ 

$$h = h_2 = 276.45 \text{ (From table)}$$

$$\text{Hence Power} = 0.2(276.45 - 237) = 7.89 \approx 7.9 \text{ kW}$$



Sol. 4

Option (D) is correct.

From the given curve, we easily see that relative humidity of air decreases, when temperature of moist air in an airtight vessel increases. So, option (C) is correct. Specific humidity remain constant with temperature increase, so option *a* & *b* are incorrect.

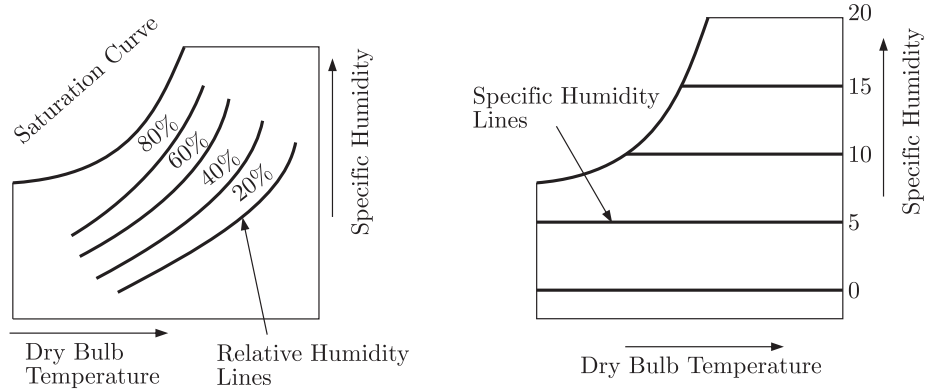

Sol. 5

Option (B) is correct.

Given :  $t_{DBT} = 30^\circ \text{C}$ ,  $W = 11.5 \text{ g water vapour/kg dry air}$   
 $p_s = 4.24 \text{ kPa}$ ,  $p = 90 \text{ kPa}$

Specific humidity,

$$W = 0.622 \left( \frac{p_v}{p - p_v} \right)$$

Substitute the values, we get

$$11.5 \times 10^{-3} = 0.622 \left( \frac{p_v}{90 - p_v} \right)$$

$$18.489 \times 10^{-3} = \frac{p_v}{90 - p_v}$$

$$(90 \times 18.489 - 18.489 p_v) \times 10^{-3} = p_v \Rightarrow p_v = 1.634 \text{ kPa}$$

Relative humidity

$$\phi = \frac{p_v}{p_s} = \frac{1.634}{4.24}$$

$$\phi = 0.3853 = 38.53\% \approx 38.5\%$$

Sol. 6

Option (A) is correct.

$p-h$  curve for vapour compression refrigeration cycle is as follows

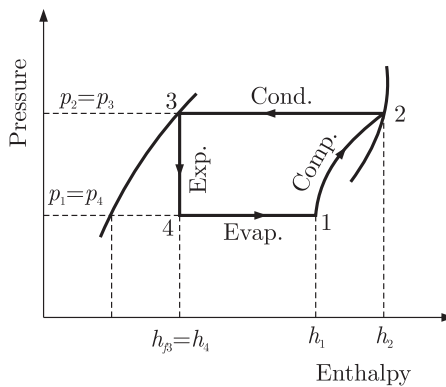

The given specific enthalpies are

Inlet of condenser  $h_2 = 283 \text{ kJ/kg}$

Exit of condenser  $h_3 = 116 \text{ kJ/kg} = h_4$

From  $p-h$  curve

Exit of evaporator  $h_1 = 232 \text{ kJ/kg}$

Now, 
$$COP = \frac{\text{Refrigerating effect}}{\text{Work done}} = \frac{h_1 - h_4}{h_2 - h_1}$$

Substitute the values, we get

$$COP = \frac{232 - 116}{283 - 232} = \frac{116}{51} = 2.27$$

Sol. 7

Option (B) is correct.

Given :  $p_1 = 100 \text{ kPa}$ ,  $p_2 = 500 \text{ kPa}$ ,  $p_{v1} = ?$

$p_{v2} = 5.628 \text{ kPa}$  (Saturated pressure at  $35^\circ\text{C}$ )

We know that,

Specific humidity 
$$W = 0.622 \left( \frac{p_v}{p - p_v} \right)$$

For case II :

$$W = 0.622 \left( \frac{5.628}{500 - 5.628} \right) = 7.08 \times 10^{-3} \text{ kg/kg of dry air}$$

For saturated air specific humidity remains same. So, for case (I) :

$$W = 0.622 \left( \frac{p_{v1}}{p_1 - p_{v1}} \right)$$

On substituting the values, we get

$$7.08 \times 10^{-3} = 0.622 \left( \frac{p_{v1}}{100 - p_{v1}} \right)$$

$$11.38 \times 10^{-3} (100 - p_{v1}) = p_{v1}$$

$$1.138 = 1.01138 p_{v1}$$

$$p_{v1} = 1.125 \text{ kPa} \approx 1.13 \text{ kPa}$$

Sol. 8

Option (C) is correct.

Given : At inlet  $t_{DBT} = 40^\circ\text{C}$ ,  $t_{WBT} = 20^\circ\text{C}$

We know that, wet bulb depression =  $t_{DBT} - t_{WBT} = 40 - 20 = 20^\circ\text{C}$

And given wet bulb depression at the exit = 25% of wet bulb depression at inlet

This process becomes adiabatic saturation and for this process,

$$t_{WBT(\text{inlet})} = t_{WBT(\text{outlet})}$$

So, 
$$t_{DBT(\text{exit})} - 20 = 0.25 \times 20$$

$$t_{DBT(\text{exit})} = 20 + 5 = 25^\circ\text{C}$$

Sol. 9

Option (B) is correct.

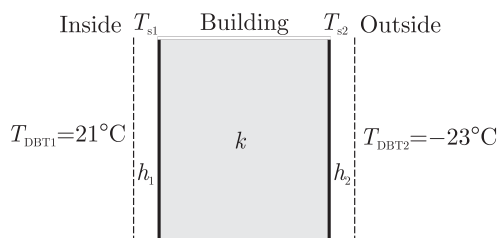

Let  $h_1$  &  $h_2$  be the internal and external surface heat transfer coefficients respectively and building wall has thermal conductivity  $k$ .

Given :  $h_1 = 8 \text{ W/m}^2 \text{ K}$ ,  $h_2 = 23 \text{ W/m}^2 \text{ K}$ ,  $k = 1.2 \text{ W/m K}$ ,  $T_{DPT} = 10.17^\circ\text{C}$

Now to prevent condensation, temperature of inner wall should be more than or equal to the dew point temperature. It is the limiting condition to prevent

condensation

So,  $T_{s1} = 10.17^\circ \text{C}$

Here  $T_{s1}$  &  $T_{s2}$  are internal & external wall surface temperature of building.

Hence, heat flux per unit area inside the building,

$$q_i = \frac{Q}{A} = h_1(T_{DBT1} - T_{s1})$$

$$q_i = 8(21 - 10.17) = 8 \times 10.83 = 86.64 \text{ W/m}^2 \quad \dots (i)$$

& Heat flux per unit area outside the building is

$$q_0 = h_2(T_{s2} - T_{DBT2}) = 23(T_{s2} + 23) \quad \dots (ii)$$

Heat flow will be same at inside & outside the building. So from equation (i) & (ii)

$$q_i = q_0$$

$$86.64 = 23(T_{s2} + 23)$$

$$T_{s2} + 23 = 3.767$$

$$T_{s2} = 3.767 - 23 = -19.23^\circ \text{C}$$

For minimum thickness of the wall, use the fourier's law of conduction for the building. Heat flux through wall,

$$q = \frac{k(T_{s1} - T_{s2})}{x} = \frac{1.2 \times (10.17 + 19.23)}{x}$$

Substitute the value of  $q_i$  from equation (i), we get

$$86.64 = \frac{1.2 \times 29.4}{x}$$

$$x = \frac{35.28}{86.64} = 0.407 \text{ m}$$

**Note :-** Same result is obtained with the value of  $q_o$

Sol. 10

Option (C) is correct.

Given :  $\dot{m}_a = 3 \text{ kg/sec}$ ,

Using subscript 1 and 2 for the inlet and outlet of the coil respectively.

$h_1 = 85 \text{ kJ/kg}$  of dry air,  $W_1 = 19 \text{ grams/kg}$  of dry air =  $19 \times 10^{-3} \text{ kg/kg}$  of dry air

$h_2 = 43 \text{ kJ/kg}$  of dry air,  $W_2 = 8 \text{ grams/kg}$  of dry air =  $8 \times 10^{-3} \text{ kg/kg}$  of dry air

$h_3 = 67 \text{ kJ/kg}$

Mass flow rate of water vapour at the inlet of the coil is,

$$\dot{m}_{v1} = W_1 \times \dot{m}_a \quad W = \frac{\dot{m}_v}{\dot{m}_a}$$

$$\dot{m}_{v1} = 19 \times 10^{-3} \times 3 = 57 \times 10^{-3} \text{ kg/sec}$$

And mass flow rate of water vapour at the outlet of coil is,

$$\begin{aligned} \dot{m}_{v2} &= W_2 \times \dot{m}_a \\ &= 8 \times 10^{-3} \times 3 = 24 \times 10^{-3} \text{ kg/sec} \end{aligned}$$

So, mass of water vapour condensed in the coil is,

$$\begin{aligned} \dot{m}_v &= \dot{m}_{v1} - \dot{m}_{v2} \\ &= (57 - 24) \times 10^{-3} = 33 \times 10^{-3} \text{ kg/sec} \end{aligned}$$

Therefore, required cooling capacity of the coil = change in enthalpy of dry air + change in enthalpy of condensed water

$$\begin{aligned} &= (85 - 43) \times 3 + 67 \times 33 \times 10^{-3} \\ &= 128.211 \text{ kW} \end{aligned}$$

Sol. 11

Option (C) is correct.

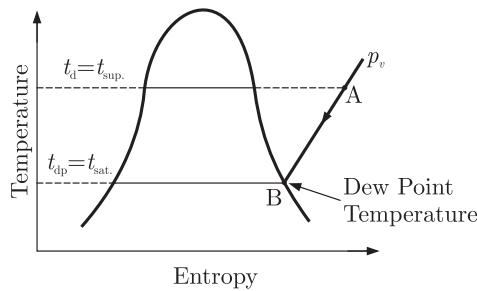

It is the temperature of air recorded by a thermometer, when the moisture (water vapour) present in it begins to condense.

If a sample of unsaturated air, containing superheated water vapour, is cooled at constant pressure, the partial pressure ( $p_v$ ) of each constituent remains constant until the water vapour reaches the saturated state as shown by point B. At this point B the first drop of dew will be formed and hence the temperature at point B is called dew point temperature.

Sol. 12

Option (A) is correct.

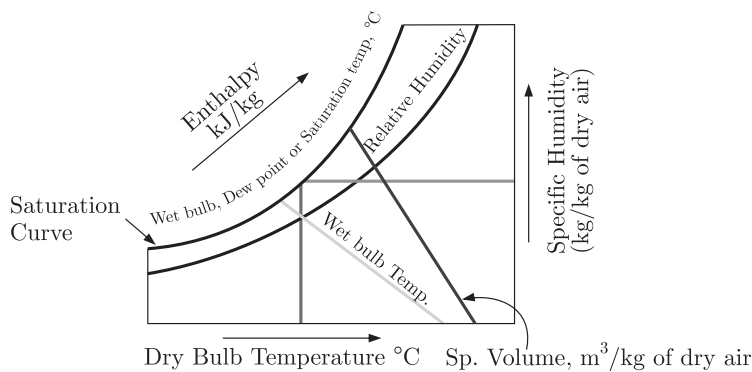

Hence, the statement 2 & 3 are correct.

Sol. 13

Option (B) is correct.

From steam table, saturated air pressure corresponding to dry bulb temperature of  $35^\circ\text{C}$  is  $p_s = 0.05628$  bar.

Relative humidity,

$$\phi = \frac{p_v}{p_s} = 0.75$$

$$p_v = 0.75 \times p_s \\ = 0.75 \times 0.05628 = 0.04221 \text{ bar}$$

Now the amount of moisture in kg/kg of dry air, (Specific Humidity) is

$$W = 0.622 \times \frac{p_v}{p_b - p_v} \qquad p_b = p_{atm} = 1.01 \text{ bar} \\ = 0.622 \times \frac{0.04221}{1.01 - 0.04221} \\ = 0.622 \times 0.04362 \\ = 0.0271 \text{ kg/kg of dry air}$$

Sol. 14

Option (B) is correct.

Given :  $t_{sp} = 42^\circ\text{C}$ ,  $t_{db} = 40^\circ\text{C}$ ,  $t_{wb} = 20^\circ\text{C}$

Here we see that  $t_{sp} > t_{db}$

Hence air gets heated, Also water is added to it, so it gets humidified.

Sol. 15

Option (A) is correct.

Given curve is the theoretical  $p-h$  curve for vapour compression refrigeration cycle.

Sol. 16

Option (B) is correct.

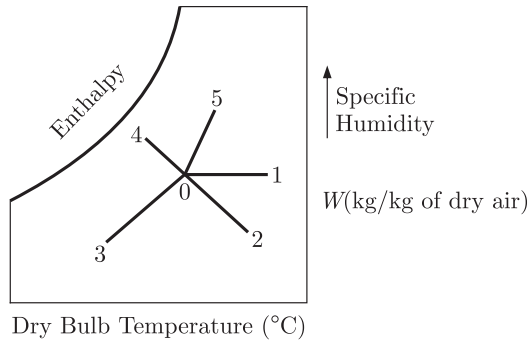

Process	Process Name	$t_{DBT}$	$W$
0-1	Sensible Heating	Increase	Constant
0-2	Chemical dehumidification	Increase	Decrease
0-3	Cooling and dehumidification	Decrease	Decrease
0-4	Humidification with water injection	Decrease	Increase
0-5	Humidification with steam injection	Increase	Increase

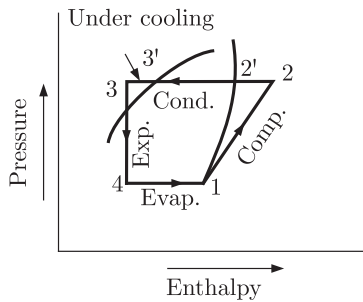

Hence, curve given in question is a ideal  $p-h$  curve for vapour compression refrigeration cycle.

Sol. 17

Option (C) is correct.

$$(COP)_{ref.} = \frac{\text{Refrigeration Effect}}{\text{Work done}} = \frac{T_1}{T_2 - T_1}$$

$$\frac{100}{W} = \frac{250}{300 - 250}$$

$$W = \frac{100}{250} \times 50 = 20 \text{ Watt}$$

For supply this work, heat is taken from reservoir 3 & rejected to sink 2.

So efficiency,

$$\eta = \frac{W}{Q_3} = \frac{T_3 - T_2}{T_3}$$

It works as a heat engine.

$$\frac{20}{Q_3} = \frac{400 - 300}{400} \Rightarrow Q_3 = 80 \text{ Watt}$$

Sol. 18 Option (A) is correct.

Air conditioner mounted in a window or through the wall are self-contained units of small capacity of 1 TR to 3 TR. The capillary tube is used as an expansion device in small capacity refrigeration units.

Sol. 19 Option (B) is correct.

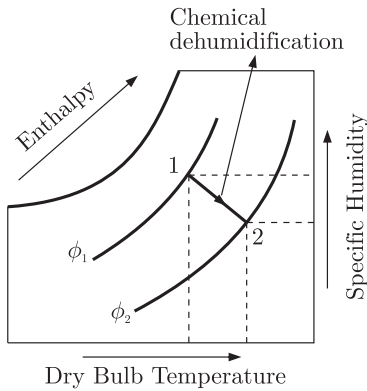

In the process of chemical dehumidification of air, the air is passed over chemicals which have an affinity for moisture and the moisture of air gets condensed out and gives up its latent heat. Due to the condensation, the specific humidity decreases and the heat of condensation supplies sensible heat for heating the air and thus increasing its dry bulb temperature.

So chemical dehumidification increase dry bulb temperature & decreases specific humidity.

Sol. 20 Option (D) is correct.

If a refrigerant is written in the form of  $Rabc$ .

The first digit on the right ( $c$ ) is the number of fluorine (F) atoms, the second digit from the right ( $b$ ) is one more than the number of hydrogen (H) atoms required & third digit from the right ( $a$ ) is one less than the Number of carbon (C) atoms in the refrigerant. So, For R134

First digit from the Right = 4 = Number of Fluorine atoms

Second digit from the right = 3 - 1 = 2 = Number of hydrogen atoms

Third digit from the right = 1 + 1 = 2 = Number of carbon atoms

Hence, Chemical formula is  $C_2H_2F_4$

Sol. 21 Option (C) is correct.

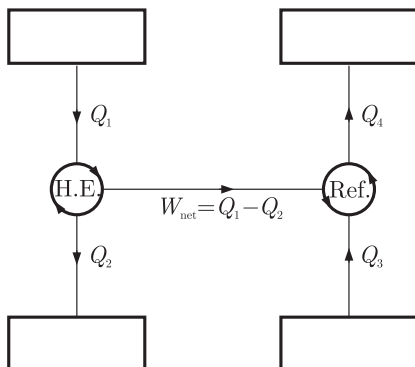

Given :  $(COP)_{refrigerator} = 5$ ,  $(\eta)_{H.E} = 70\% = 0.7$

$$(COP)_{ref.} = \frac{Q_3}{W} = 5 \quad \dots(i)$$

$$(\eta)_{H.E} = \frac{W}{Q_1} = 0.7 \quad \dots(ii)$$

By multiplying equation (i) & (ii),

$$\frac{Q_3}{W} \times \frac{W}{Q_1} = 5 \times 0.7 \quad \Rightarrow \quad \frac{Q_3}{Q_1} = 3.5$$

Hence, Energy absorbed ( $Q_3$ ) from low temperature reservoir by the refrigerator for each  $kJ$  of energy absorbed ( $Q_1$ ) from high temperature source by the engine = 3.5 kJ

Sol. 22

Option (B) is correct.

Given :  $t_{dp} = 18^\circ \text{C} = (273 + 18) \text{K} = 291 \text{K}$ ,  $p = p_{atm} = 1.013 \text{bar}$

$t_{db} = 30^\circ \text{C} = (273 + 30) \text{K} = 303 \text{K}$

$p_v = 0.02062 \text{bar}$  (for water vapour at dew point).

$c_{air} = 1.005 \text{kJ/kg K}$ ,  $c_{water} = 1.88 \text{kJ/kg K}$

Latent heat of vaporization of water at  $0^\circ \text{C}$ .

$$h_{fgdp} = 2500 \text{kJ/kg}$$

Specific humidity,

$$\begin{aligned} W &= \frac{0.622 \times p_v}{p - p_v} = \frac{0.622 \times 0.02062}{1.013 - 0.02062} \\ &= \frac{0.01282}{0.99238} = 0.01291 \text{ kg/kg of dry air} \end{aligned}$$

Enthalpy of moist air is given by,

$$\begin{aligned} h &= 1.022 t_{db} + W(h_{fgdp} + 2.3 t_{dp}) \text{ kJ/kg} \\ &= 1.022 \times 30 + 0.01291 [2500 + 2.3 \times 18] \\ &= 30.66 + 0.01291 \times 2541.4 = 63.46 \text{ kJ/kg} \approx 63.15 \text{ kJ/kg} \end{aligned}$$

Sol. 23

Option (A) is correct.

Given :  $C = 0.03$ ,  $n = 1.15$ , Specific volume at suction =  $0.1089 \text{m}^3/\text{kg}$

$$\begin{aligned} \text{Net refrigeration effect} &= 2 \text{ ton} \quad 1 \text{ TR} = 1000 \times 335 \text{ kJ in 24 hr} \\ &= \frac{2 \times 1000 \times 335}{24 \times 60 \times 60} = 7.75 \text{ kJ/sec} \end{aligned}$$

Let net mass flow rate =  $\dot{m}$

Net refrigeration effect =  $\dot{m}(h_1 - h_4)$

Substitute the values from equation (i), and from the  $p$ - $h$  curve,

$$\begin{aligned} 7.75 &= \dot{m}(176 - 65) \\ m &= \frac{7.75}{111} = 0.06981 \text{ kg/sec} \end{aligned}$$

Specific volume,  $\frac{\nu}{\dot{m}} = 0.1089$

$$\nu = 0.1089 \times 0.06981 = 0.00760 = 7.60 \times 10^{-3} \text{ m}^3/\text{sec}$$

We know that volumetric efficiency,

$$\eta_v = 1 + C - C \left( \frac{p_2}{p_1} \right)^{\frac{1}{n}}$$

Where,  $p_1$  is the suction pressure and  $p_2$  is the discharge pressure.

$$= 1 + 0.03 - 0.03 \times \left(\frac{7.45}{1.50}\right)^{\frac{1}{1.15}}$$

$$= 1.03 - 0.12089 = 0.909$$

Now actual volume displacement rate is,

$$\nu_{actual} = \nu \times \eta_v = 7.60 \times 10^{-3} \times 0.909$$

$$= 6.90 \times 10^{-3} \simeq 6.35 \times 10^{-3} \text{ m}^3/\text{sec}$$

Sol. 24

Option (C) is correct.

Given :  $T_1 = 27^\circ \text{C} = (27 + 273) \text{K} = 300 \text{K}$ ,

$T_2 = -13^\circ \text{C} = (-13 + 273) \text{K} = 260 \text{K}$ ,  $Q_1 = 1000 \text{W}$ ,  $Q_2 = 750 \text{W}$

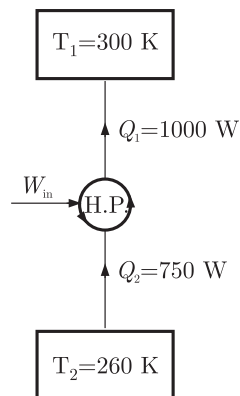

So,

$$(COP)_{H.P.} = \frac{Q_1}{Q_1 - Q_2} = \frac{1000}{1000 - 750} = 4$$

**Alternate Method :**

From energy balance

$$W_{in} + Q_2 = Q_1$$

$$W_{in} = Q_1 - Q_2 = 1000 - 750 = 250 \text{W}$$

And

$$(COP)_{H.P.} = \frac{\text{Desired effect}}{W_{in}} = \frac{Q_1}{W_{in}} = \frac{1000}{250} = 4$$

Sol. 25

Option (B) is correct.

We know that for saturated air, the relative humidity is 100% and the dry bulb temperature, wet bulb temperature and dew point temperature is same. But when air is not saturated, dew point temperature is always less than the wet bulb temperature.

$$\text{DPT} < \text{WBT}$$

Sol. 26

Option (A) is correct.

Given :  $T_1 = T_4 = -20^\circ \text{C} = (-20 + 273) \text{K} = 253 \text{K}$ ,  $\dot{m} = 0.025 \text{kg/sec}$

$T_2 = T_3 = 40^\circ \text{C} = (40 + 273) \text{K} = 313 \text{K}$

From the given table,

At,  $T_2 = 40^\circ \text{C}$ ,  $h_2 = 200 \text{kJ/kg}$

And  $h_3 = h_4 = 80 \text{kJ/kg}$



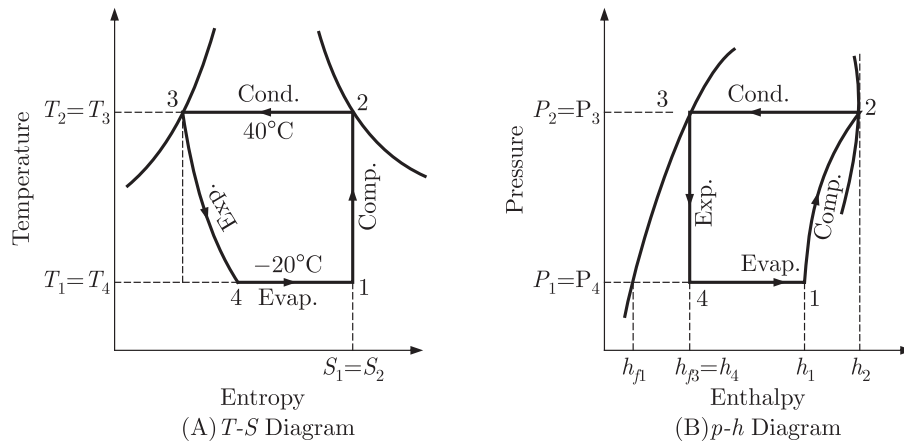

From the given  $T$ - $s$  curve

$$s_1 = s_2$$

$$s_2 = s_f + x s_{fg}$$

$x$  = Dryness fraction

{ $s_2$  is taken 0.67 because  $s_2$  at the temperature  $40^\circ\text{C}$  & at 2 high temperature and pressure vapour refrigerant exist.}

$$0.67 = 0.07 + x(0.7366 - 0.07)$$

$$s_{fg} = s_g - s_f$$

$$0.67 - 0.07 = x \times 0.6666$$

$$0.6 = x \times 0.6666$$

$$x = \frac{0.6}{0.6666} = 0.90$$

And Enthalpy at point 1 is,

$$h_1 = h_f + x h_{fg} = h_f + x(h_g - h_f)$$

$$= 20 + 0.90(180 - 20) = 164 \text{ kJ/kg}$$

Now refrigeration effect is produce in the evaporator.

Heat extracted from the evaporator or refrigerating effect,

$$R_E = \dot{m}(h_1 - h_4) = 0.025(164 - 80) = 2.1 \text{ kW}$$

Sol. 27

Option (B) is correct.

$$\begin{aligned} (COP)_{\text{refrigerator}} &= \frac{h_1 - h_4}{h_2 - h_1} = \frac{\text{Refrigerating effect}}{\text{Work done}} \\ &= \frac{164 - 80}{200 - 164} = \frac{84}{36} = 2.33 \end{aligned}$$

\*\*\*\*\*